

8274-1

PLANETARY GRINDER INSTRUCTION MANUAL



Caution: Read Manual Before Operating Machine

Table of Contents

Table of Contents	3
Features and Specs.....	4
Safety.....	5-8
General Rules For Safe Operation	5-6
Characteristics of a Defensive Operator.....	6
Silica Dust Warning	6
Grounding.....	7
Extension Cords	7
Power Source Voltage	8
Machine Operations	9-10
Load and Unload	9
Handle Assembly.....	9
Vacuum Port.....	9
Rubber Dust Guard.....	9
Weights.....	10
Machine Start Up Procedure	10
Accessory Set-up	11-12
Accessory Set-up.....	11
Accessory Attachment.....	12
Magnetic Tooling	13-15
Metal Bond.....	13
Braze Trapezoid.....	13
PCD's & Carbides.....	13
Sandpaper Disks	14
Accessories for the 8274	14
Versatile Floating Action for 8274	14
5" Braze Diamonds.....	15
Polishing Pads.....	15
Diamond Sanding Pads.....	15
Maintenance.....	16-21
General Maintenance	16
Maintaining Tools.....	16
Cleaning.....	16
Repairs	16
Belt Procedures	17
Accessing Belt	17
Removing Belt	17
Replacing Belt.....	18
Idle Bearing Replacement	19
Pulley Replacement.....	19
Satellite Shaft Replacement	19
Satellite Bearing Replacement	20
Removing Top Gear Plate.....	21
Cord Plug Light.....	21
Troubleshooting	22
Controller Fault Codes.....	22
Parts and Diagrams.....	23-26
Complete Parts List	23
Handle Parts.....	24
External Parts	24
18" Deck Assembly.....	25
Labels	26
Guarantee.....	27

Features and Specifications



FEATURES

Adjustable Handle - Adjusts in three locations for operator comfort.

Dust Collector Port - Located in the back of the machine to ensure the hose will not get in the way and halt production.

Flip Style Weights - Allows an operator to easily add down pressure when required.

90° Rotating Grinder Deck - Granting easy access to the quick change magnetic tooling.

Control Box - The self diagnosing control box has a variable speed feature that minimizes blown circuit breakers.

1.5 HP Motor - National's unique engineered control box allows the grinders 230 volt 1.5 hp motor to operate using 115 volt power.

Adjustable Rubber Dust Guard - Provides a dustless operation.

Product Specifications

Width	Height	Length	Weight	Disc Size	Voltage	HP	Motor
20.25" (51.43 cm)	37.5" (95.25 cm)	35.75" (90.8 cm)	391 lbs (177.35 kg)	18" (45.72 cm)	115	3	Single Phase Operation

GENERAL RULES FOR SAFE OPERATION

READ AND SAVE ALL INSTRUCTIONS FOR FUTURE USE. Before use, be sure everyone operating this equipment reads and understands this manual as well as any labels packaged with or attached to the machine and components and view the instruction video. Additional copies of the manual and video are available upon request.

1. **KNOW YOUR EQUIPMENT:** Read this manual carefully to learn equipment applications and limitations as well as potential hazards associated with this type of equipment. Keep this manual with the equipment it is associated with.
2. **GROUND YOUR TOOL:** See Grounding Page 7.
3. **AVOID DANGEROUS ENVIRONMENTS:** Do not use in rain, damp or wet locations, or in the presence of explosive atmospheres (gaseous fumes, dust or flammable materials). Remove materials or debris that may be ignited by sparks.
4. **KEEP WORK AREA CLEAN AND WELL LIT:** Cluttered, dark work areas invite accidents.
5. **DO NOT USE ON STEPS.**
6. **DRESS PROPERLY:** Do not wear loose clothing. These may be caught in moving parts. When working wear gloves and insulated non-skid footwear. Keep hands and gloves away from moving parts.
7. **USE SAFETY EQUIPMENT:** Everyone in the work area should wear safety goggles or glasses complying with current safety standards. Wear hearing protection during extended use and a dust mask depending on jobsite conditions. Hard hats, face shields, safety shoes, etc. should be worn when specified or necessary.
8. **KEEP BYSTANDERS AWAY:** Children and other bystanders should be kept at a safe distance from the work area to avoid distracting the operator and contacting the tool or extension cord. Operator should be aware of who is around them and their proximity. This equipment is not intended for use by persons (including children) with reduced physical, sensory or mental capabilities, or lack of experience and knowledge, unless they have been given supervision or instruction concerning use of the equipment by a person responsible for their safety. Children should be supervised to ensure that they do not play with the machine.
9. **PROTECT OTHERS IN THE WORK AREA:** Provide barriers or shields as needed to protect others from debris.
10. **USE PROPER ACCESSORIES:** Using accessories that are not recommended may be hazardous. Be sure accessories are properly installed and maintained. Do not delete a guard or other safety device when installing an accessory or attachment.
11. **CHECK FOR DAMAGED PARTS:** Inspect guards and other parts before use. Check for misalignment, binding of moving parts, improper mounting, broken parts and any other conditions that may affect operation. If abnormal noise or vibration occurs, turn the tool off immediately and have the problem corrected before further use. Do not use damaged equipment. Tag damaged tools "DO NOT USE" until repaired. A missing/damaged guard or other damaged parts should be properly repaired or replaced. For all repairs, insist on only identical National replacement parts.
12. **REMOVE ALL ADJUSTING KEYS AND WRENCHES:** Make a habit of checking that the adjusting keys, wrenches, etc. are removed from the tool before turning it on.
13. **GUARD AGAINST ELECTRIC SHOCK:** Prevent body contact with grounded surfaces such as pipes, radiators, ranges and appliances. When operating equipment, always check the work area for hidden wires or pipes. Operate the equipment by holding insulated nonmetal grasping surfaces. Use a Ground Fault Circuit Interrupter (GFCI) to reduce shock hazards.
14. **AVOID ACCIDENTAL STARTING:** Be sure equipment is turned off before plugging it in. Do not use equipment if the power switch does not turn the tool on and off.
15. **DO NOT FORCE EQUIPMENT:** Equipment will perform best at the rate for which it was designed. Excessive force only causes operator fatigue, increased wear and reduced control.
16. **KEEP HANDS AWAY FROM ALL CUTTING EDGES AND MOVING PARTS.**
17. **WEAR GLOVES** when changing accessories.
18. **DO NOT ABUSE CORD:** Never unplug by pulling the cord from the outlet. Pull plug rather than cord to reduce the risk of damage. Keep the cord away from heat, oil, sharp objects, cutting edges and moving parts.
19. **DO NOT OVERREACH. MAINTAIN CONTROL:** Keep proper footing and balance at all times. Maintain a firm grip.
20. **STAY ALERT:** Watch what you are doing, and use common sense. Do not use when you are tired, distracted or under the influence of drugs, alcohol or any medication causing decreased control.
21. **STARTING MACHINE:** On/off switch must be in the off position before connecting to power source.
22. **UNPLUG EQUIPMENT:** When it is not in use and before changing accessories or performing recommended maintenance unplug machine.

Safety

23. **MAINTAIN EQUIPMENT CAREFULLY:** Keep handles dry, clean and free from oil and grease. Keep cutting edges sharp and clean. Follow instructions for lubricating and changing accessories. Periodically inspect tool cords and extension cords for damage. Have damaged parts repaired or replaced. Insist on only identical National replacement parts.
24. **STORE IDLE EQUIPMENT:** When not in use, store in a dry, secured place. Keep away from children.
25. **MAINTAIN LABELS AND NAMEPLATES:** These carry important information. If unreadable or missing, contact National for a replacement.
26. **MACHINE IS HEAVY, DO NOT DROP.**
27. **WHEN OPERATING MACHINE:** tether cord must be connected to operator.
28. **DO NOT ALLOW** the rotating plates or tooling to come into contact with the supply cord.
29. **REGULARLY EXAMINE** the supply cord for damage, such as cracking or aging. If damage is found, replace the cord before further use. Only replace the supply cord with the type specified in the instruction manual.

CHARACTERISTICS OF A DEFENSIVE OPERATOR

A Good Operator is a "Defensive" Operator!!

QUALITIES INCLUDE:

Education: Learns about the machine and the environment.

Alert: Stays alert at all times...never lets guard down.

Skills: Only performs duties he/she are qualified to do. Always tries to improve.

Judgment: Plays it safe. Doesn't take chances.

Common Sense: Does the right thing without having to be told. Applies knowledge.

Recognizes the Hazards: Maintains alertness. Anticipates danger.

Understands the Defense: Knows that safety isn't an accident...it's a thinking person's choice.

Acts Correctly: Does not cave in to peer pressure. Performs correctly when supervised or not.



WARNING: SILICA DUST WARNING SCRAPING/GRINDING/CUTTING/DRILLING OF MASONRY, CONCRETE, METAL AND OTHER MATERIALS CAN GENERATE DUST, MISTS AND FUMES CONTAINING CHEMICALS KNOWN TO CAUSE SERIOUS FATAL INJURY OR ILLNESS, SUCH AS RESPIRATORY DISEASE, CANCER, BIRTH DEFECTS OR OTHER REPRODUCTIVE HARM. IF YOU ARE FAMILIAR WITH THE RISKS ASSOCIATED WITH THE PARTICULAR MATERIAL BEING REMOVED OR PREPARED, REVIEW THE MATERIAL SAFETY DATA SHEET AND/OR CONSULT YOUR EMPLOYER, THE MATERIAL MANUFACTURER/SUPPLIER, GOVERNMENTAL AGENCIES SUCH AS OSHA AND NIOSH AND OTHER AUTHORITIES ON HAZARDOUS MATERIALS. CALIFORNIA AND SOME OTHER AUTHORITIES, FOR INSTANCE, HAVE PUBLISHED LISTS OF SUBSTANCES KNOWN TO CAUSE CANCER, REPRODUCTIVE TOXICITY, OR OTHER HARMFUL EFFECTS. CONTROL DUST, MIST AND FUMES AT THE SOURCE WHERE POSSIBLE. IN THIS REGARD USE GOOD WORK PRACTICES AND FOLLOW THE RECOMMENDATIONS OF THE MANUFACTURER/SUPPLIER, OSHA/NIOSH, AND OCCUPATIONAL AND TRADE ASSOCIATIONS. WHEN THE HAZARDS FROM INHALATION OF DUST, MISTS AND FUMES CANNOT BE ELIMINATED, THE OPERATOR AND ANY BYSTANDERS SHOULD ALWAYS WEAR A RESPIRATOR APPROVED BY OSHA/MSHA FOR THE MATERIAL BEING REMOVED OR PREPARED.

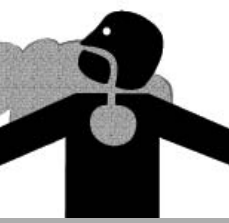



WARNING: ELECTRICAL CORDS CAN BE HAZARDOUS. MISUSE CAN RESULT IN FIRE OR DEATH BY ELECTRICAL SHOCK. READ CAREFULLY AND FOLLOW ALL DIRECTIONS.

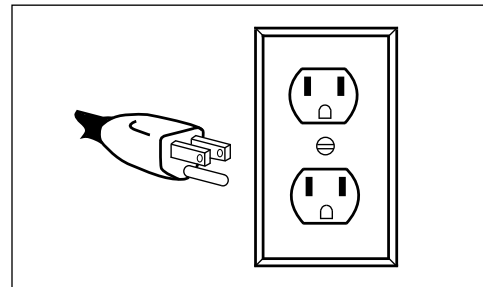

FIG. A

GROUNDING

Jobsite receptacles can vary. Check the voltage at different receptacles on the jobsite for a more accurate voltage reading. 15 amp GFI outlets are not recommended.



CAUTION: IMPROPERLY CONNECTING THE GROUNDING WIRE CAN RESULT IN THE RISK OF ELECTRIC SHOCK. CHECK WITH A QUALIFIED ELECTRICIAN IF YOU ARE IN DOUBT AS TO WHETHER THE OUTLET IS PROPERLY GROUNDED. DO NOT MODIFY THE PLUG PROVIDED WITH THE EQUIPMENT. NEVER REMOVE THE GROUNDING PRONG FROM THE PLUG. DO NOT USE THE EQUIPMENT IF THE CORD OR PLUG IS DAMAGED. IF THE PLUG WILL NOT FIT THE OUTLET, HAVE A PROPER OUTLET INSTALLED BY A QUALIFIED ELECTRICIAN.

GROUNDING EQUIPMENT: EQUIPMENT WITH THREE PRONG PLUGS

Equipment marked "Grounding Required" have a three wire cord and three prong grounding plug. The plug must be connected to a properly grounded outlet (Figure A). If the equipment should electrically malfunction or break down, grounding provides a low resistance path to carry electricity away from the user; reducing the risk of electric shock.

The grounding prong in the plug is connected through the green wire inside the cord to the grounding system in the equipment. The green wire in the cord must be the only wire connected to the equipment's grounding system and must never be attached to an electrically "live" terminal.

The equipment must be plugged into an appropriate outlet, one which is properly installed and grounded in accordance with all codes and ordinances. The plug and outlet should look like the example in Figure A.

EXTENSION CORDS

Grounded equipment requires a three wire extension cord. Double insulated equipment can use either a two or three wire extension cord. As the distance from the supply outlet increases, you must use a heavier gauge extension cord. Using extension cords with inadequately sized wire causes a serious drop in voltage, resulting in loss of power and possible equipment damage.

The smaller the gauge number of the wire, the greater the capacity of the cord. For example, a 10 gauge cord can carry a higher current than a 12 gauge cord. When using more than one extension cord to make up the total length, be sure each cord contains at least the minimum wire size required. If you are using one extension cord for more than one tool, add the nameplate ampere and use the sum to determine the required minimum wire size.

GUIDELINES FOR USING EXTENSION CORDS

- If you are using an extension cord outdoors, make sure it is marked with the suffix "W-A" ("W" in Canada) to indicate that it is acceptable for outdoor use.
- Be sure your extension cord is properly wired and in good electrical condition. Always replace a damaged extension cord or have it repaired by a qualified person before using it.
- Protect your extension cords from sharp objects, excessive heat and damp or wet areas.

Safety

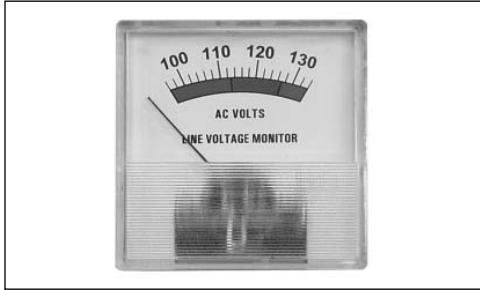

FIG. B



FIG. C

GUIDELINES FOR USING EXTENSION CORDS (CONTINUED)

- Keep away from water. Do not use if wet.
- Inspect thoroughly before each use. **DO NOT USE IF DAMAGED.**
- Make sure equipment is not running before disconnecting cord.
- **FULLY INSERT** plug into outlet.
- Do not remove, bend or modify any metal prongs or pins of cord.
- Do not use excessive force to make connections.
- Do not connect a three prong plug to a two-hole cord.
- Avoid overheating. Uncoil cord and do not cover it with any material.
- Do not walk on cord.
- Do not drive, drag or place objects over cord.
- Use a 12 gauge, 115v cord, 50ft maximum length with this machine. (Included with purchase.)
- Regularly examine the supply cord for damage, such as cracking or aging. If damage is found, replace the cord before further use.
- Only replace the supply cord with the type specified in the instruction manual.

POWER SOURCE VOLTAGE - FOR 115 VOLTAGE

Jobsite receptacles can vary. Check voltage at receptacles on the jobsite for the best voltage supply. 15 amp GFI outlets are not recommended.

NOTE: KITCHEN, BATHROOM, OUTDOOR AND GARAGE RECEPTACLES MAY BE GFI. GFI RECEPTACLES CAN BE "SENSITIVE". SOME GFI RECEPTACLES WILL NOT ALLOW THE MACHINE TO RUN. TO TEST THE OUTLET, GO TO SWITCH BOX AND CHECK CIRCUITS. TURN OFF TO TEST.

National recommends using a voltage meter that easily plugs into any outlet to determine the amount of voltage at that specific outlet.

The use of a #5110-500 Buck and Boost Transformer (Figure B) improves voltage out of a 115 volt receptacle.

Machine Operation

LOAD AND UNLOAD

- Always disconnect from the power source before transporting.
- Loosen Handle Securing Bolt to slide handle down to make machine easier to load. Retighten Bolts when handle is at the desired height.

HANDLE ASSEMBLY



CAUTION: HANDLE MUST BE ENGAGED WITH BOTH SECURING BOLTS. FAILURE TO DO SO COULD CAUSE SERIOUS INJURY.

Handle adjusts to the operators height. Loosen the handle bolt and adjust the handle (Figure D) to the desired length and properly tighten bolt. Handle adjusts in both height and angle. Adjust handle grip to desired angle and firmly secure (Figure E). Adjust handle to desired angle and secure with clip the support pin (Figure F).

VACUUM PORT



WARNING: MAKE SURE TO USE THE PROPER INDUSTRIAL HEPA DUST COLLECTOR BASED ON THE TYPE OF SURFACE APPLICATION. FAILURE TO DO SO COULD CAUSE EMISSIONS OF HAZARDOUS PARTICULATES DUE TO FINE DUST. MAKE SURE THE SYSTEM YOU ARE USING COMPLIES OR EXCEEDS OSHA RECOMMENDED STANDARD. MAKE SURE THE RUBBER DUST GUARD IS SECURE AND COVERS ALL THE WAY TO THE FLOOR SURFACE.

The machine incorporates a dust collection port located at the rear of the machine. Use a dust collection hose that snugly fits either on the outside or the inside of the port.

Connect vacuum hoses (Figure G). An industrial dust collector hose attaches to the rear dust collection port (A). The dual short hose connection runs from the grinder deck to the 'Y' splitter (B).

RUBBER DUST GUARD



WARNING: NEVER OPERATE THE MACHINE WITHOUT THE RUBBER DUST GUARD PROPERLY IN PLACE. MAKE SURE THE DUST GUARD FORMS A SEAL FROM THE GRINDER DECK TO THE FLOOR. FAILURE TO DO SO COULD CAUSE SERIOUS HARM TO THE OPERATOR AND/OR PATRONS IN PROXIMITY TO THE GRINDER.

NEVER MOUNT OR RE-ADJUST THE RUBBER DUST GUARD WITH THE MACHINE PLUGGED IN. DISCONNECT IT FROM THE POWER SOURCE BEFORE MOUNTING OR RE-ADJUSTING THE RUBBER DUST GUARD.

ATTACHING

Return machine to upright position. Attach dust guard (Figure H) keeping as close to the floor as possible. If dust is exposed when operating machine, stop machine and readjust dust guard.



FIG. D



FIG. E



FIG. F

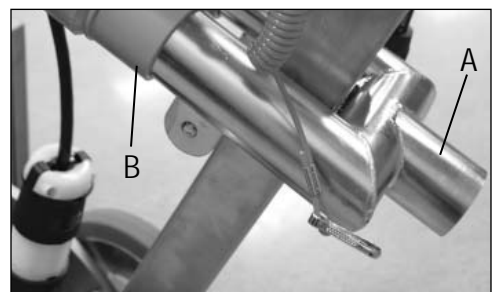

FIG. G



FIG. H

Machine Operation



FIG. I



FIG. J

POSITIONING

Unplug machine from power source. With machine sitting in the operating position, remove rubber dust guard held on by Velcro. Starting at one end of the shroud, place guard to rest on floor surface. Firmly press rubber guard into securing Velcro on shroud. Wrap rubber guard all the way around the shroud making sure the guard rests on the floor surface and is secure (See Figure I). Inspect for air gaps between dust guard and floor.

If rubber guard securing Velcro becomes loaded up with debris, wash out with mild soap or blow out with an air hose. If Velcro on the machine is damaged or worn out, replace before using the machine. If the rubber guard is cut, damaged or worn out, replace before using the machine. Safety glasses need to be worn by operator and all people working around the equipment.

WEIGHTS

Weights rotate front to back. To apply added weight to head, one or both weights can be rotated forward (Figure I). To take load off machine, pull weights to the back (Figure J). If circuit breakers trips at the power source, pull weight(s) to the back to reduce head pressure.

MACHINE START UP PROCEDURE

Prior to starting the grinder the operator must:

- Ensure all floating isolator assemblies and magnetic tooling plates are securely fastened.
- Clean any dust or debris from the magnetic tooling holders prior to installing tooling or Velcro adapter plates.
- Install the desired tooling based on the jobsite application requirements.
- Connected the proper dust collector to the grinder.
- Ensure the dust guard is properly in place by forming a seal from the grinder deck to the surface of the floor being prepared.
- Attach the tether cord to both the machine and the operator.

INSTALLING THE 9292 FLOATING ISOLATOR ASSEMBLIES & MAGNETIC TOOLING HOLDER

- Prior to operating the grinder, begin by tilting the machine back; pushing down on the operator handle and rotating the grinding deck back a full 90 degrees to expose the underside or tooling side of the grinder deck.
- Before installing the three 9292 floating isolator assemblies, it is necessary to first remove the three magnetic tooling plates from the underside of the grinder deck.
- Using a 7/32 T-handle wrench, remove the 3/8x16x7/8 flathead cap socket screw from the center of each magnetic tooling plate.
- Next remove the three tooling plates and set them aside to be reinstalled onto the 9292 isolator assemblies.
- Locate a "button head" cap screw on the top of each 9292 isolator assembly.
- Apply a small amount of Blue Loctite on the end of each of the three assemblies.
- Center the isolators on the scrubber shaft.
- Insert the T-handle Allen Wrench onto the button head cap socket screw in the center of the isolator assembly.
- Carefully avoid cross threading the screw while tightening firmly.
- Locate the three magnetic tooling plates previously set aside.
- Using a 7/32 T-handle wrench, secure each magnetic tooling plate firmly using 3/8x16x7/8 flathead cap socket screw. (Note: it is usually not necessary to use any loctite when installing the tooling plate screws.)

TURNING MACHINE ON

1. Plug the controller into a 50 foot 12 gauge extension cord.
2. Plug the extension cord into a 15 amp or 20 amp, 115 volt power supply.
3. Attach the control box safety tether to the operator's wrist.
4. Move the FWD/REV toggle switch to the desired "forward" or "reverse" position. (Figure K; A)
5. The operator should apply a light amount of pressure to the grinder handle to relieve the initial torque created when starting the machine.
6. Move the power toggle switch to the "ON" position (Figure K; B).

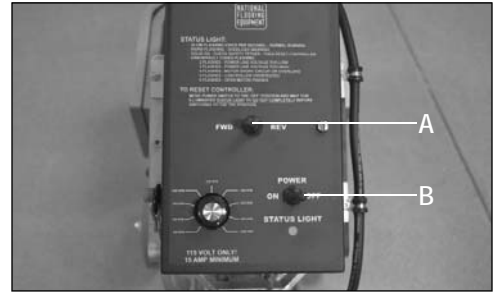

FIG. K

TURNING MACHINE OFF

To turn the grinder off move the toggle switch to the "OFF" position.

ACCESSORY SET-UP

When determining the proper tooling for any job you need to consider the end result you want to achieve. When grinding, down pressure relates to two aspects: first the amount of weight applied at a given point and second the surface area upon which the weight is being distributed at a given point. If tooling with a smaller segment is used the amount of down pressure applied at the point of contact between the segment and the surface is increased. Using larger segments will decrease the amount of down pressure. More or less down pressure will directly affect production rates and the type of profile achieved.

If more down pressure is desired you can insert the tooling segments into just two of the four magnetic pockets. In this case make sure to insert the tooling into the magnetic pockets directly across from one another.

The machine is designed to run in forward or reverse for most applications. PCDs and carbides can only be used in forward motion.

With the grinder deck in the "tool changing" position when the control box switch is in the "forward" position the satellites should turn clockwise (Figure L); while the drum should turn counterclockwise (Figure L).

Reversely, with the grinder deck in the "tool changing" position when the control box switch is in the "reverse" position the satellites should turn counterclockwise (Figure M); while the drum should turn clockwise (Figure M).

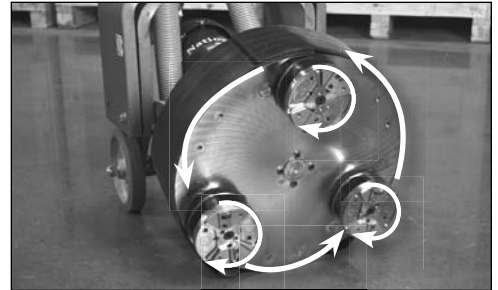

FIG. L

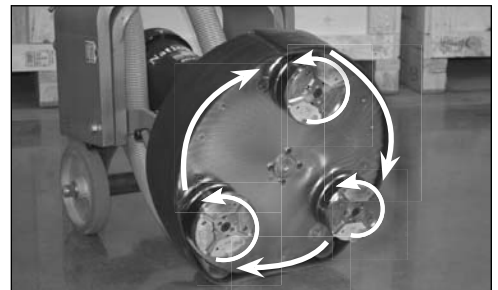

FIG. M



WARNING: DO NOT LEAVE A PLUGGED-IN MACHINE UNATTENDED. IMPROPER CONNECTION OF THE EQUIPMENT-GROUNDING CONDUCTOR CAN RESULT IN A RISK OF ELECTRICAL SHOCK. CHECK WITH A QUALIFIED ELECTRICIAN OR SERVICE PERSON IF YOU ARE IN DOUBT AS TO WHETHER THE OUTLET IS PROPERLY GROUNDED. DO NOT MODIFY THE PLUG PROVIDED WITH THIS UNIT. IF IT WILL NOT FIT THE OUTLET, HAVE A PROPER OUTLET INSTALLED BY A QUALIFIED ELECTRICIAN. NOTE: IN CANADA, THE USE OF A TEMPORARY ADAPTER IS NOT PERMITTED BY THE CANADIAN ELECTRICAL CODE. IMPROPER USE OF THE GROUNDING PLUG CAN RESULT IN A RISK OF ELECTRICAL SHOCK.

KNOW WHAT YOU ARE REMOVING. SCRAPING, SANDING OR GRINDING CAN RELEASE HEALTH HAZARDOUS DUST AND LIQUIDS. MAKE SURE YOU ARE FOLLOWING OSHA, STATE AND/OR FEDERAL GUIDELINES WHEN REMOVING HAZARDOUS MATERIALS. TAKE NECESSARY PRECAUTIONS AND PROCEDURES. ON SOME MATERIALS, GRINDING, SCRAPING OR SANDING IS NOT ALLOWED.

Machine Operation



FIG. N

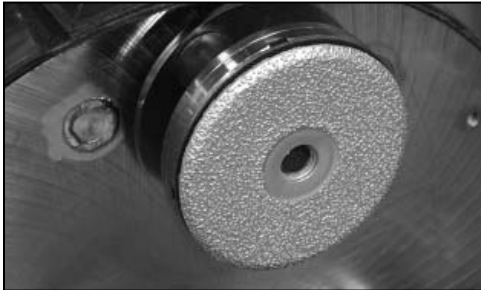

FIG. O



FIG. P

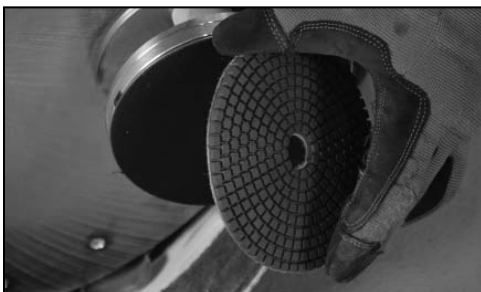

FIG. Q

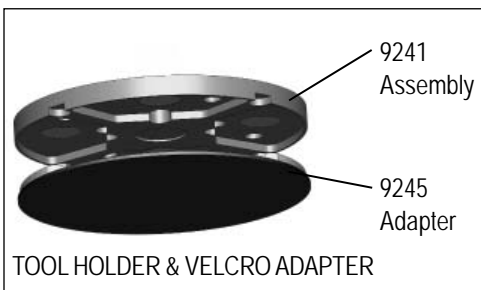

FIG. R

ACCESSORY ATTACHMENT

Many choices of accessories are available when grinding; to include: removal, profiling and polishing.

To expose the underside of the machine, tilt motor back to expose the grinders tool changing position.

Place the individual tooling segments into two or four of the magnetic pockets. Be careful not to pinch your fingers as the tooling segments will snap into place as the magnetic connection is made. For safety, depending on the condition of the surface being prepared, the individual tooling segments should be attached to the magnetic tooling holders using a single mounting screw for each segment.

ATTACHING THE VELCRO PLATE ADAPTER

The Velcro plate adapter attaches magnetically to the Magnetic tooling plate and snaps into place.

MOUNTING BRAZED DIAMOND AND POLISHING PADS

The brazed diamond and polishing pads are attached to the Velcro adapter plates.

MOUNTING PCD'S

PCD's are mounted to the tooling holder with the 9550 tooling screws. The tooling holder and PCD's are not magnetic but rather are attached to the magnetic plates.

When setting the machine down into the operating position, hold the machine firmly, set it down gently, DO NOT drop. Damage to accessories and machine could occur if dropped.

 **WARNING:** WHEN ACCESSORIES ARE EXPOSED, NEVER OPERATE MACHINE. SERIOUS INJURY AND POSSIBLE PLATE DISENGAGEMENT COULD OCCUR.

METAL BOND (FIGURE S)

Utilized for light, medium and aggressive concrete grinding and profiling as well as sealer & top coat removal. Can be used for both residential and industrial applications. Perfect for leveling concrete high spots and repairing imperfections as well as creating the perfect profile for accepting new coatings, epoxies or preparing concrete for polishing.



FIG. S



FIG. T

PART#	DESCRIPTION	GRIT	
1	9507-6	6 GRIT METAL BOND HALF SEGMENT DIAMOND	6
2	9507-12	12 GRIT METAL BOND HALF SEGMENT DIAMOND	12
3	9507-16	16 GRIT METAL BOND HALF SEGMENT DIAMOND	16
4	9507-16-HB	16 GRIT METAL BOND HALF SEGMENT DIAMOND (HARD)	16
5	9507-30	30 GRIT METAL BOND HALF SEGMENT DIAMOND	30
6	9507-30-HB	30 GRIT METAL BOND HALF SEGMENT DIAMOND (HARD)	30
7	9508-16	16 GRIT METAL BOND FULL SEGMENT DIAMOND	16
8	9508-16-SB	16 GRIT METAL BOND FULL SEGMENT DIAMOND (SOFT)	16
9	9508-30	30 GRIT METAL BOND FULL SEGMENT DIAMOND	30
10	9508-30-SB	30 GRIT METAL BOND FULL SEGMENT DIAMOND (SOFT)	30
11	9510-30	30 GRIT METAL BOND PROFILING DIAMOND	30
12	9510-50	50 GRIT METAL BOND PROFILING DIAMOND	50
13	9510-120	120 GRIT METAL BOND PROFILING DIAMOND	120
14	73081	TOOLING MOUNT SCREW	--

PCD'S & CARBIDES (FIGURE T & U)

Designed for aggressive concrete stock removal as well as coatings, glues, mastics and other floor covering adhesives.



FIG. U

PART#	DESCRIPTION		
1	7268-2	CARBIDE - 4 SIDED	FIGURE C
2	9554	1-UP, 1/2 ROUND PCD	FIGURE B
3	9556	2-UP, 1/2 ROUND PCD	FIGURE B
4	9557	4-UP MICRO PCD	FIGURE B
5	9521	TOOLING HOLDER	
6	9550	TOOLING SCREW	
7	73097	TOOL HOLDER MOUNTING BOLT (FOR 8274)	

ACCESSORIES FOR 8274 (FIGURE V)

Tooling mounts on to assembly.

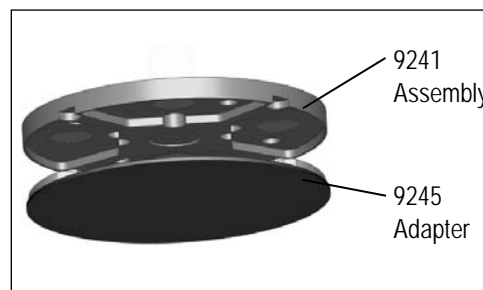

FIG. V

PART#	DESCRIPTION	
1	9241	MAGNETIC TOOL HOLDER ASSEMBLY
2	9245	VELCRO ADAPTER

VERSATILE FLOATING ACTION FOR 8274

The national 9292 floating head assembly improves machine performance. Ideal for reaching into low spots (bird baths) and leveling high spots by following the undulation of the surface. Insures a uniform and consistent scratch pattern by allowing the tooling to flex. Tooling plates attach directly onto mounted floating assembly. Three assemblies required.

PART#	DESCRIPTION	
1	9292	5" FLOATING ASSEMBLY WITH SPACER (INDIVIDUAL)
2	73214	FLOATING ASSEMBLY MOUNTING SCREW

Tooling



FIG. W

5" BRAZED DIAMONDS (FIGURE W)

Utilized primarily in industrial applications for medium to aggressive concrete grinding & profiling as well as sealer and top coat removal. Perfect for concrete preparation & restoration prior to concrete polishing. In addition, brazed diamonds effortlessly remove stains and imperfections from exterior wood decking while simultaneously providing wood profile for receiving new stains and/or sealers.

	PART#	DESCRIPTION	GRIT
1	9235-16	16 GRIT 5" BRAZED DIAMOND	16
2	9235-30	30 GRIT 5" BRAZED DIAMOND	30
3	9235-50	50 GRIT 5" BRAZED DIAMOND	50
4	9235-100	100 GRIT 5" BRAZED DIAMOND	100

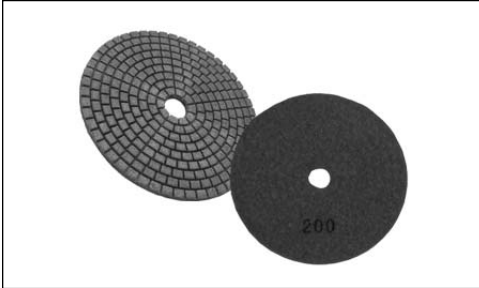

FIG. X

POLISHING PADS (FIGURE X)

Utilized for polishing concrete to various finishes and shines. Resin bond. Available in escalating grit.

	PART#	DESCRIPTION	GRIT
1	9267-50	50 GRIT 5" POLISHING PAD	50
2	9267-100	100 GRIT 5" POLISHING PAD	100
3	9267-200	200 GRIT 5" POLISHING PAD	200
4	9267-400	400 GRIT 5" POLISHING PAD	400
5	9267-800	800 GRIT 5" POLISHING PAD	800
6	9267-1500	1500 GRIT 5" POLISHING PAD	1500
7	9267-3000	3000 GRIT 5" POLISHING PAD	3000
8	9267-BUFF	BUFF 5" POLISHING PAD	BUFF

Machine Maintenance

MAINTENANCE

A well-maintained machine is a productive machine. If not properly maintained, it could be unsafe and inoperable. A scheduled maintenance program should insure a long system life and a safe work environment.

1. Always wear eye protection.
2. Keep flammable and fragile objects away from the tool.
3. Always check nuts and bolts to make sure they are tight.
4. Always use the tool with proper voltage specified on the machine's nameplate.
5. Always keep guards in place.
6. Do not operate around water or wet conditions without use of GFI on cord.
7. Use properly grounded cord and receptacle.
8. Unplug from power before servicing.
9. Use 12 gauge or heavier wire cord, not exceeding 50 feet in length.
10. Do not force machine.
11. Do not alter machine.
12. Keep wheels free from debris.
13. Maintain Labels. These carry important information. If unreadable or missing, contact National to order replacement labels.

MAINTAINING EQUIPMENT

Keep in good repair by adopting a regular maintenance program. Before use, examine the general condition. Inspect guards, switches, grinder cord and extension cord for damage. Check for loose screws, misalignment, binding of moving parts, improper mounting, broken parts and any other condition that may affect its safe operation. If abnormal noise or vibration occurs, turn the grinder off immediately and have the problem corrected before further use. Tag damaged tool, "Do Not Use" until repaired.

- Mechanical inspection and cleaning (pulleys, belts, bearings, nuts, bolts, housing, labels, etc.).
- Electrical inspection (switch, cord, plugs, etc.).
- Test to assure proper mechanical and electrical operation.

CLEANING

Clean dust and debris from wheels and housing. Keep the grinder handle clean, dry and free of oil or grease. Use only mild soap and a damp cloth to clean your tool since certain cleaning agents and solvents are harmful to plastics and other insulated parts. Some of these include: gasoline, turpentine, lacquer thinner, paint thinner, chlorinated cleaning solvents, ammonia and household detergents containing ammonia. Never use flammable or combustible solvents around machinery. Do Not pressure wash grinder. Getting motor or control box wet could cause electric shock or damage the grinders electrical components.

- Never use machine wet.
- Replace missing or worn labels. Labels contain important safety and operational information.

REPAIRS

If your machine is damaged, call for a return/repair authorization number and return to:

NATIONAL FLOORING EQUIPMENT, INC.
9250 XYLON AVENUE
MINNEAPOLIS, MN 55445
(763) 535-8206 • 800-245-0267

- Shipments are not accepted without a return authorization number
- COD or freight collect shipments will not be accepted



WARNING: TO REDUCE THE RISK OF INJURY, ELECTRIC SHOCK AND DAMAGE TO THE GRINDER, NEVER IMMERSE IT IN LIQUID OR ALLOW A LIQUID TO FLOW INSIDE THE GRINDER OR IT'S ELECTRICAL COMPONENTS.

Machine Maintenance



FIG. Y



FIG. Z

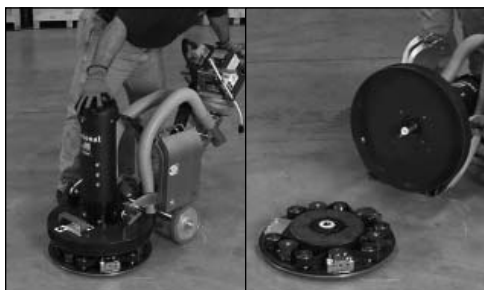

FIG. AA

FIG. BB



FIG. CC

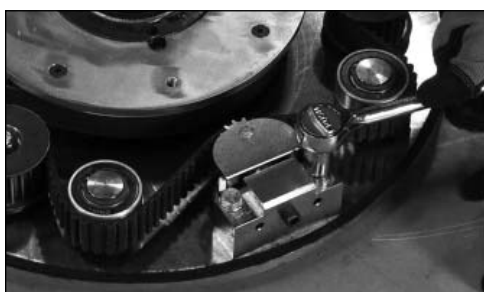

FIG. DD

BELT PROCEDURES



CAUTION: BEFORE ANY MAINTENANCE, MAKE SURE MACHINE IS DISCONNECTED FROM POWER SOURCE

TO ACCESS BELT

1. If present, remove the 9292 Floating Head assemblies prior to accessing or replacing the belt.
2. Remove the dust guard (Figure Y).
3. Remove the four bolts on top of the shroud cover (Figure Z).
4. Push down on the handle. The shroud should lift up and away from the grinding deck. If not, with the four bolts on top of the shroud cover removed, tip the grider deck back to the tool changing position. Insert a 1/2"-13X4" threaded bolt into the center of the underside of the deck plate. Turn bolt in clockwise until deck is free of grinder shroud. Remove bolt, tilt deck back into the operating position and the shroud should now lift up and away from the grinding deck (Figure AA).
5. Move machine back and off the plate (Figure BB).

REMOVING BELT

1. Remove any dust or debris from inside deck.
2. Using an allen wrench install the 5/16-18x1 1/4" socket head cap screws (#73349) into each tensioner and compress the block spring by turning the screw clockwise.
3. The belt should be loose enough to slide off.
4. Leave approximately 1/8" gap when compressing the block spring to allow clearance for removing the tensioner mounting bolts (Figure CC).
5. Remove one mounting bolt completely, loosen the other (Figure DD).
6. Continue with the belt replacement instructions. (See page 17).

Machine Maintenance

REPLACING BELT

1. Deck should now be in orientation shown before installing new belt, clean any debris from the deck before moving on (Figure EE).
2. Install belt around the center gear, pull the excess through the gap by the counter weight (Figure FF).
3. Keep the smooth side of the belt against the idlers and flip the belt over the deck, the teeth on the belt will face outward (Figure FF).
4. A properly installed belt should appear as shown (Figure GG).
5. Turn one tensioner into place and install the bolt (Figure HH).
6. Push the second tensioner into the belt until the mounting hole lines up with the block and install the second bolt.
7. Once both tension blocks are installed remove the collapsing bolts.
8. Use pliers to rotate the shaft on the bottom of the machine so the key is in the 12 o'clock position (Figure II).
9. Turn the deck so the key way in the hub is also in the 12 o'clock position (Figure JJ).
10. Hold the motor straight while lining up the shaft with the hub in the deck.
11. Press evenly on the top of the motor or deck until the shroud is seated on the deck.
12. Re-install the four bolts around the base of the reducer, it may be necessary to rotate the shroud to line up the holes. (Take care not to crossthread bolts when installing).
13. Test machine thoroughly to ensure correct operation.



FIG. EE



FIG. FF



FIG. GG

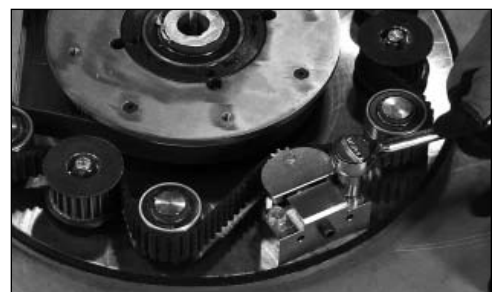

FIG. HH

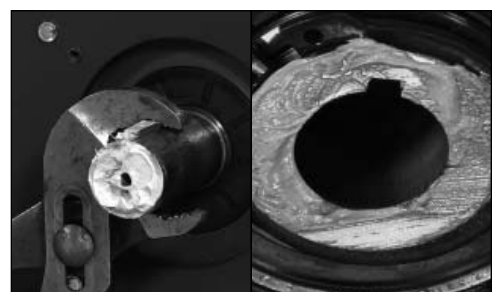

FIG. II

FIG. JJ

Machine Maintenance



FIG. KK

IDLE BEARING REPLACEMENT

1. Remove belt, following **REMOVING BELT** instructions (page 16).
2. Remove snap ring (Figure KK).
3. Remove idler bearings (Figure LL) .
4. Replace bearing.
5. Replace snap ring, making sure ring is seated in the groove (Figure KK).
6. Reinstall belt.



FIG. LL

PULLEY REPLACEMENT

1. Remove belt, following **REMOVING BELT** instructions (Page 16).
2. Remove nut from top of pulley.
3. Slide pulley up and off. Key will fall out (Figure MM).
4. Replace key in new pulley.
5. Line up key in pulley.
6. Install pulley.
7. Reinsert nut.
8. Reinstall belt following the **REPLACING BELT** instructions (Page 17).



FIG. MM

SATELLITE SHAFT REPLACEMENT

1. Remove pulley following 1-3 of **PULLEY REPLACEMENT** instructions above.
2. Push down on shaft (Figure NN).
3. Lift up on plate and pull out shaft (Figure OO).
4. Replace shaft (Figure PP).
5. Replace Pulley following 4-6 of **PULLEY REPLACEMENT** instructions above.
6. Replace nut.
7. Reinstall belt following the **REPLACING BELT** instructions (Page 17).



FIG. NN



FIG. OO

SATELLITE BEARING REPLACEMENT

1. Remove pulley following 1-3 of the **PULLEY REPLACEMENT** instructions (Page 18).
2. Remove satellite shaft (Figure PP).
3. Block up plate (Figure QQ).
4. Knock out bearing (Figure RR) .
5. Turn plate over on blocks.
6. With the retainer ring turned upwards, replace the bearing (Figure SS) keeping the bearing as straight as possible (Figure TT) Note: Bearing can be difficult to get inserted.
7. Replace shaft.
8. Replace pulley following 4-6 of **PULLEY REPLACEMENT** instructions (Page 18).
9. Replace nut.
10. Reinstall belt following the **REPLACING BELT** instructions (Page 17).

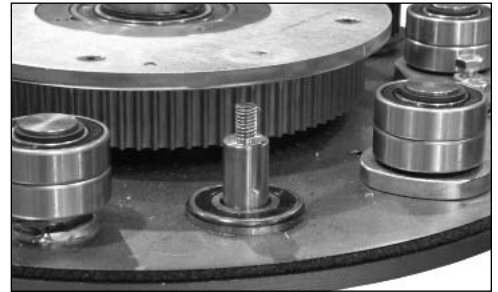

FIG. PP

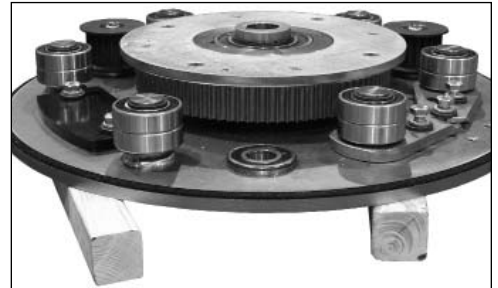

FIG. QQ

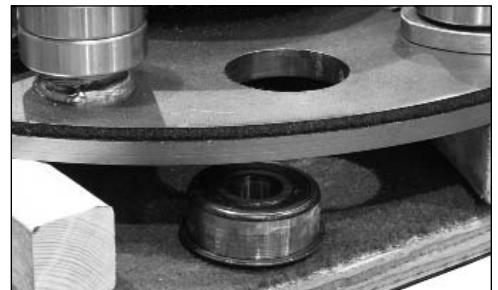

FIG. RR



FIG. SS



FIG. TT

Machine Maintenance



FIG. UU



FIG. VV

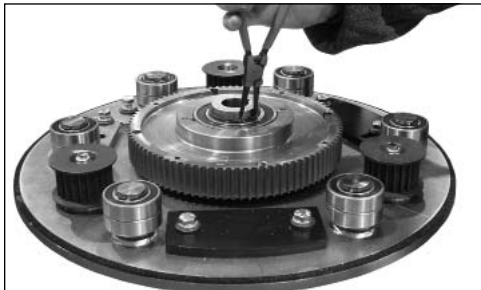

FIG. WW

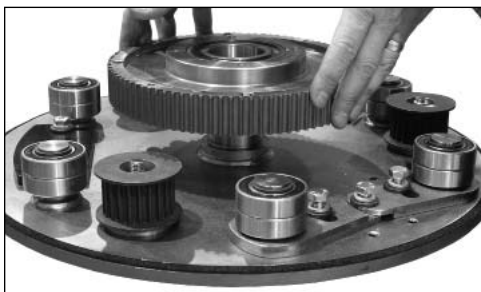

FIG. XX

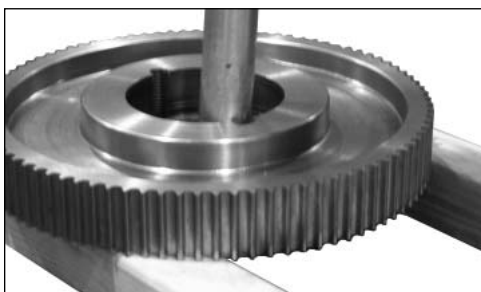

FIG. YY

REMOVING TOP GEAR PLATE

1. Remove belt, following **REMOVING BELT** instructions.
2. With a 4mm allen wrench, remove the four gear plate cover screws (Figure UU).
3. Remove gear plate (Figure VV).
4. Remove both snap rings (Figure WW).
5. Remove gear (Figure XX).
6. Block up gear (Figure YY).
7. Knock out bearings.
8. Reinstall bearings one at a time Note: Hitting around the outside perimeter of the bearing, keep the bearing as straight as possible.
9. Replace gear back onto plate keeping fingers clear (Figure XX).
10. (Caution: pinch point), wiggle bearing until it drops down. Do Not Force.
11. Reinsert snap rings making sure they are seated in the groove.
12. Reinsert gear plate.
13. Reinsert four screws.
14. Reinstall belt.

Troubleshooting Guide

Fault Code Status Light	Fault Description	Problem	Solution
SOLID ON	Check safety tether	Safety Tether is disconnected from controller or faulty connection internally with the tether switch.	Test Attach the safety tether to the control box. If necessary, check connections inside the controller. Make sure the control box is disconnected from the power source prior to opening the control box.
2 FLASHES	Power line voltage too low	Not enough power coming into the controller to start or run the grinder.	Use a 50 foot 12 gauge extension cord only. Too long of an extension cord can lower the voltage input. If power source is a generator ensure it is a minimum 10 Kilowatt and its 115 volt output is working properly.
3 FLASHES	Power line voltage too high	Excessive power coming into controller to start or run the grinder.	Make sure the grinder is plugged into a 115 volt outlet. If power source is a generator ensure it is a minimum 10 Kilowatt and its 115 volt output is working properly.
4 FLASHES	Motor short circuit or overload	Check to make sure controller is plugged into 115 volt circuit that is functioning properly. Motor may be overheating due to using too long of an extension cord.	Let motor cool before attempting to reset the fault code. Reduce the amp draw by removing weights from the grinder deck and/or reducing the motor's RPMs. Use maximum 50 foot, minimum 12 gauge extension cord.
5 FLASHES	Controller overheating	Internal components of the controller are too hot.	Make sure the external fan is plugged into the controller and it is working properly. Reduce the amp draw by removing weights from the grinder deck and/or reducing the motor's RPMs.
6 FLASHES	Open motor phases	No power from the controller motor	Make sure the motor is properly connected to the control box.
NO FLASHING LIGHTS or ANY LIGHTS AT ALL	No illuminated status lights or fault codes	No illuminated status lights or fault codes. Ensure the power cord is plugged into a working 115 volt power source. (Reset power supply circuit breaker if necessary.) If unit is properly connected to a working power source, it is likely the 25 amp fuse inside the control box is blown.	Prior to opening the control box, make sure it is disconnected from the power source. In addition, it may take as much as 30 seconds for the power to discharge from the capacitors inside the control box after it has been disconnected from the power source. Replace the industrial 25 amp fuse. (National Part #400347)

Complete Parts List

PART#	DESCRIPTION	QTY	PART#	DESCRIPTION	QTY		
1	80024	BLOCK, PLANETARY HANDLE	1	18	8274-CONTROLLER CONTROLLER 115V, 1 PH, VFD	1	
2	80026	TUBE, OVAL, PLANETARY HANDLE	1	19	8274-27	PULLEY, 90 TOOTH	1
3	80035	TUBE, INNER WELDMENT	1	20	8274-33	PLATE, PULLEY	1
4	80036	TUBE, OUTER WELDMENT	1	21	8274-64	PLANETARY, 18"	1
5	80037	FRAME, PLANETARY HANDLE	1	22	8274-68	TENSIONER, PLANETARY BELT	1
6	80038	HANDLE ASSEMBLY (COMPLETE)	1	23	8274-69	WEIGHT, COUNTER	1
7	80039	SPLITTER, VAC	1	24	71222	BEARING, 20MM ID	3
8	8274-46	BRACKET, CONTROLLER 8274	1	25	71232	BEARING, 20MM ID 1DC	12
9	400390	PLATE, MOUNTING, CONTROLLER	2	26	73037	BOLT, FLAT HEAD SOCKET CAP 1/4-20X14	
10	400124	HOSE, VACUUM 2" DIA, 3' CUT, W/CUFFS2		27	73208	BOLT, HEX HEAD CAP 3/8-16X1-1/2	4
11	7274-200	WHEEL	2	28	73237	WASHER, HARDENED DIE 3/8	11
12	80059	WEIGHT, 1/2" PLANETARY HANDLE	2	29	73904	KEY, 3/16X3/16X3/4	3
13	8274-7-SV	SHROUD, 18"	1	30	80043	PULLEY, 22 TOOTH	3
14	8274-45	GUARD, RUBBER DUST	1	31	80049	SHAFT, SCRUBBER, WELDMENT	3
15	8274-53	ASSEMBLY, COMPLETE	1	32	L106	LABEL, PINCH POINT	1
16	9274-39-SV	HANDLE, FRONT, STRAIGHT	1	33	402003	LABEL, NATIONAL LOGO SMALL	1
17	9274-43-SV	HANDLE, REAR WELDMENT	1	34	402036	LABEL, 8274-1 LOGO	1

Parts List and Diagrams

PART#	DESCRIPTION	QTY	
1	80024	BLOCK, PLANETARY HANDLE	1
2	80026	TUBE, OVAL, PLANETARY HANDLE	1
3	80035	TUBE, INNER WELDMENT	1
4	80036	TUBE, OUTER WELDMENT	1
5	80037	FRAME, PLANETARY HANDLE	1
6	80038	HANDLE ASSEMBLY (COMPLETE)	1
7	80039	SPLITTER, VAC	1
8	8274-46	BRACKET, CONTROLLER 8274	1
9	400390	PLATE, MOUNTING, CONTROLLER	2

HANDLE PARTS

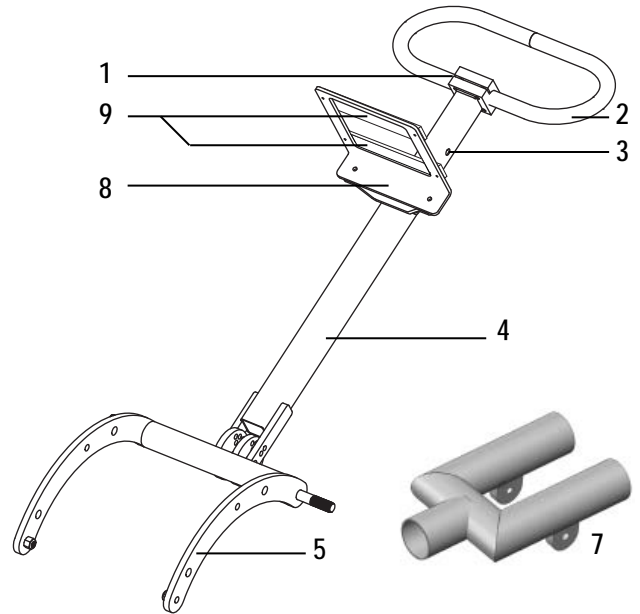

PART#	DESCRIPTION	QTY	
1	400124	HOSE, VACUUM 2" DIA, 3' CUT, W/CUFFS	2
2	7274-200	WHEEL	2
3	80059	WEIGHT, 1/2" PLANETARY HANDLE	2
4	8274-7-SV	SHROUD, 18"	1
5	8274-45	GUARD, RUBBER DUST	1
6	8274-53	ASSEMBLY, COMPLETE	1
7	9274-39-SV	HANDLE, FRONT, STRAIGHT	1
8	9274-43-SV	HANDLE, REAR WELDMENT	1
9	8274-CONTROLLER	CONTROLLER 115V, 1 PH, VFD	1

EXTERNAL PARTS



Parts List and Diagrams

18" DECK ASSEMBLY

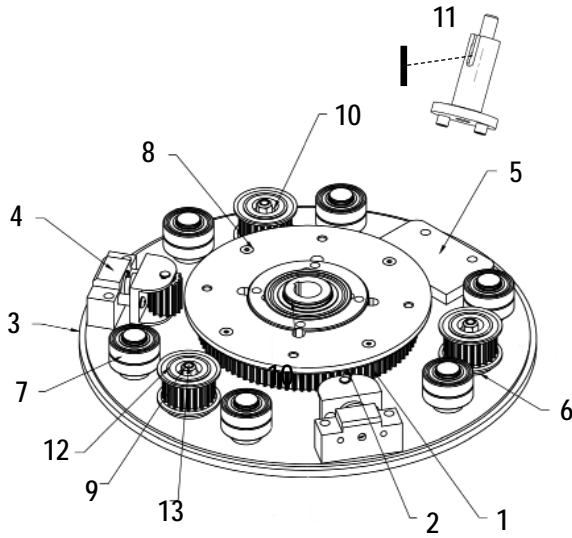

	PART#	DESCRIPTION	QTY
1	8274-27	PULLEY, 90 TOOTH	1
2	8274-33	PLATE, PULLEY	1
3	8274-64	PLANETARY, 18"	1
4	8274-68	TENSIONER, PLANETARY BELT	1
5	8274-69	WEIGHT, COUNTER	1
6	71222	BEARING, 20MM ID	3
7	71232	BEARING, 20MM ID 1DC	12
8	73037	BOLT, FLAT HEAD SOCKET CAP 1/4-20X1	4
9	73208	BOLT, HEX HEAD CAP 3/8-16X1-1/2	4
10	73237	WASHER, HARDENED DIE 3/8	11
11	73904	KEY, 3/16X3/16X3/4	3
12	80043	PULLEY, 22 TOOTH	3
13	80049	SHAFT, SCRUBBER, WELDMENT	3

Parts List and Diagrams

LABELS



PART#	DESCRIPTION	QTY	PART#	DESCRIPTION	QTY
1	L106	2	3	402036	1
2	402003	2		LABEL, 8274-1 LOGO	



Guarantee

National Flooring Equipment, Inc. (National) warrants to the first consumer/purchaser that this National brand product (**8274-1 Planetary Grinder System**) when shipped in its original container, will be free from defective workmanship and materials and agrees that it will, at its option, either repair the defect or replace the defective product or part thereof at no charge to the purchaser for parts or labor for the period(s) set forth below.

This warranty does not apply to any appearance items of the product, to the additional excluded items set forth below, or to any product, the exterior of which has been damaged or defaced, which has been subjected to misuse, abnormal service or handling, or which has been altered or modified in design or construction.

In order to enforce the rights under this limited warranty, the purchaser should follow the steps set forth below and provide proof of purchase to National.

The limited warranty described herein is in addition to whatever implied warranties may be granted to purchasers by law. All implied warranties including the warranties of merchantability and fitness for use are limited to the periods from the date of purchase as set forth below. Some states do not allow time limitations on an implied warranty, so the above limitation may not apply to you.

Neither the sales person of the seller, nor any other person, is authorized to make any other warranties other than those described herein, or to extend the duration of any warranties beyond the time period described herein on behalf of National.

The warranties described herein shall be the sole and exclusive warranties granted by National and shall be the sole and exclusive remedy available to the purchaser. Correction of defects in the manner and for the period of time described herein, shall constitute complete fulfillment of all liabilities and responsibilities of National to the purchaser with respect to the product and shall constitute full satisfaction of all claims, whether based on contract, negligence, strict liability or otherwise. In no event shall National be liable, or in any way responsible for any damage or defects in the product which were caused by repairs or attempted repairs performed by anyone other than National. Nor shall National be liable, or in any way responsible, for any incidental or consequential, economics or property damage. Some states do not allow the exclusion of incidental or consequential damages, so the above exclusion may not apply to you.

This warranty gives you specific legal rights. You may also have other rights which vary from state to state.

WARRANTY PERIOD

The **8274-1 Planetary Grinder System** is guaranteed to be free of manufacturer defective workmanship and in quality of materials for a period of one year.

Items excluded from warranty coverage, unless found and reported defective immediately upon removal from the original shipping container and before being used by the original purchaser.

A freight damage claim must be filed with the carrier by the purchaser, the shipper cannot file the freight claim.

TO OBTAIN SERVICE CONTACT NATIONAL FLOORING EQUIPMENT, INC. TOLL FREE AT 800-245-0267 FOR A REPAIR AUTHORIZATION NUMBER. COD FREIGHT RETURNS WILL NOT BE ACCEPTED. FREIGHT COLLECT SHIPMENTS WILL NOT BE ACCEPTED. WARRANTY REPAIRS MUST BE ACCOMPANIED BY DATE OF PURCHASE RECEIPT AND A RETURN/REPAIR AUTHORIZATION NUMBER.

RETURN/REPAIR AUTHORIZATION NUMBER: _____

MACHINE SERIAL NUMBER: _____



Made in America Since 1968

9250 Xylon Avenue N • Minneapolis, MN 55445 • U.S.A.
Toll-free 800-245-0267 • Phone 763-315-5300 • Fax 800-648-7124 • Fax 763-535-8255
Web Site: www.nationalequipment.com • E-Mail: info@nationalequipment.com